

2012 STANDARD EQUIPMENT

CONSTRUCTION

Closed cell PVC foam coring
Deck mechanically fastened and fiberglass bonded to hull
Fiberglass uni-grid stringer system
Hand-laid with multidirectional biaxial & triaxial knitted fiberglass
High density ceramic matrix core transom
Inner liner integrally bonded to hull
No wood-no rot laminated design
Posi-stern hull pad design
Solid fiberglass bottom
Vinylester resin barrier to prevent osmotic blistering

COCKPIT

Coaming Bolsters
Anchor locker, top loading
Bait prep center w/53 gal. stand-up livewell, tackle storage, cushion, rod holders, F/W sink w/shower
Boarding ladder & grab rail
Fishboxes - 2 ea. 104 gal. w/macerator drains (FS Models)
Forward hand rails
Fresh water washdown
Molded fiberglass gasketed hatches
Non-skid decks, with self bailing cockpit Rod holders, 6 ea.
Rod racks, 4 pr.
Rod storage lockers, 2 ea. - 7 cu. ft., lockable
Safety equipment storage lockers
Salt water washdown
Storage compartment forward, 14 cu. ft.
Storage compartments, 2 ea. - 12 cu. ft.
Transom door & gate
Helm seat w/drink holders & folding footrest.

ELECTRICAL

All wiring tin coated copper
Automatic battery management system
Battery charger, multi-bank
Battery parallel switch
Bonded electrical system
Circuit protection throughout
Cockpit lighting, indirect LED
Color coded & numbered wiring system
Courtesy light in console
Hi-water bilge alarm
International navigation lights
Marine horn, electric, dual
Switch panel w/indicator lights, custom
Weather resistant switches
HD marine batteries, AGM

MECHANICAL

All fasteners, hinges and hardware are stainless steel
Bilge pumps, automatic/manual (2) 2000 GPH
Bronze thru-hull fittings below waterline
Deck hardware, flush mounted, SS
Double SS hose clamps below waterline
Fuel filters/water separator(s) 10 micron
Fuel tanks, HD marine aluminum, coal tar coated
Heavy duty vinyl rub rail with SS insert
Sea-cocks on all below water thru-hulls
Trim tabs, recessed w/auto retract and indicators
Water tank w/gauge
Livewell pump, HD 1600 GPH

WARRANTY:

All Jupiter models are covered by a lifetime transferable limited warranty.

CONSOLE

Battery storage compartment
Compass, high speed
Console seat with cushions & handrails
Custom SS steering wheel
Easy access entry door to head, lockable
Electronics compartment at helm
Marine head, electric w/holding tank
Molded insulated drink cooler 85 qt.
Plexiglass windscreen
Power outlet, 12V
Recessed key switches
Safety gear compartment
Custom oversize console w/stand-up head ventilating hatch and easy access door

RIGGING

Electronic binnacle control w/power trim
Engine alarm system
Engine cables & harness
Fuel/water sensor w/alarm
Hull boot stripe w/accent
Hydraulic steering w/adjustable helm
SS propellers matched to engines
Power Assist Steering
Premium multifunction instrumentation to include: tachometers, voltmeter, hour meters, fuel gauges, water gauges, fuel monitoring system

CUDDY

Convertible dinette
Hi-lo teak table
Refrigerator 12V/110V (AC/DC)
Teak cabin sole
Deck hatch, ventilating



2012 PRICING

	F/S	TOURNAMENT	CUDDY
Twin Yamaha F350, 4-stroke	\$288,900	\$293,900	\$299,990
Triple Yamaha F300, 4-stroke	\$323,800	\$328,800	\$334,890
Triple Yamaha F350, 4-stroke	\$335,900	\$340,900	\$346,990

GENERAL

Custom Towing Bit, HD Stainless Steel..... 3,320
GPS Mast, 3-Prong 695
Painted Hull Sides, Awlcraft..... 5,990
Painted Engines, Awlcraft, each 1,860
Paint underside of hardtop 1,450
Teak trim package, helm footrest and gauge trim..... 1,190

MECHANICAL/ELECTRICAL

Bow thruster 8,975
Electronics/Stereo Package, factory installed P.O.R.
Extra fuel, 80 gal * 4,840
Extra fuel, 155 gal. *(Std w/triple engines) 5,750
Cockpit Lighting, 2 color upgrade 295
Underwater Lights, Xenon HID, each 1,945
Underwater lights, LED, each 1,445
Windlass w/SS anchor and line 5,580

CUDDY

Air conditioning w/30A shore power 6,880
Microwave 595
Flat Screen TV with DVD 1,450
Fwd bulkhead seating, recessed 3,150
Bow rail, low profile..... 2,490

COCKPIT/FISHING

Custom T-top; oversize, fiberglass hardtop 13,950
T-top, extended, 6 leg w/oversize hardtop..... 18,950
T-Top Tower w/2nd Station Controls P.O.R.
Electronics box 2,990
Outriggers, T-top mounted..... 2,295
Extra rod holders, gunnel mounted, pr. 295
Transom mounted 15° Rod Holders 210
Dive Door, Port side entry..... P.O.R.
Coffin Box, Tournament Model 4,450
Prep Center with Mezzanine seating*** 1,980
Transom mounted livewell ** P.O.R.

CANVAS & CUSHIONS

Console cover helm/electronics..... 295
Prep Center Cover..... 590
Forward filler platform with cushion 1,810
Dodger w/zip-out window 1,970
Double Helm seats w/flip up bolsters 3,490
Stern seat, recessed..... 3,940
Two-tone upholstery upgrade 2,990
Console Enclosure, Polycarbonate 1,790
Console Enclosure, 3-Sided 3,190

* In lieu of fwd. storage compartment

** Not available w/stern seat

***In lieu of standard prep center

Contact your local dealer or the factory for full listing of custom options

JUPITER THIRTY-EIGHT

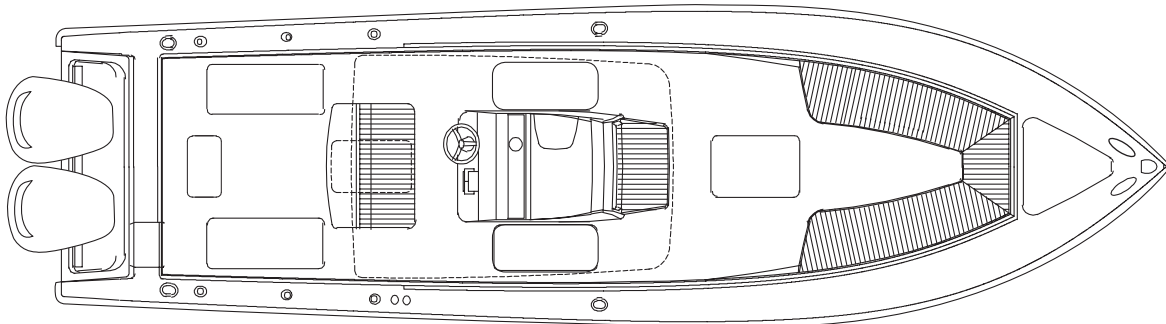
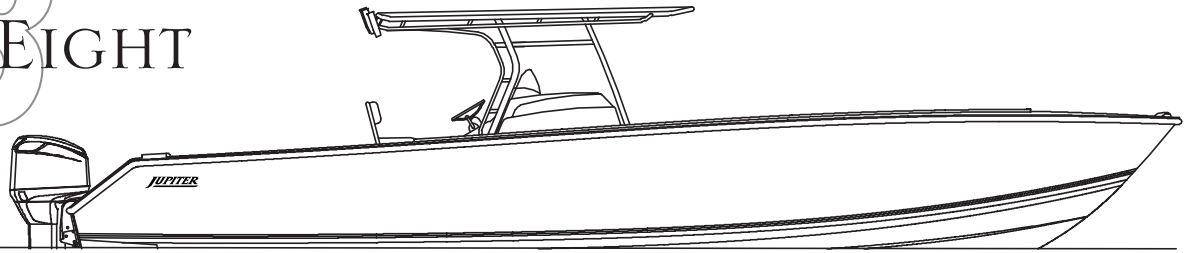

Jupiter 38 Forward Seating

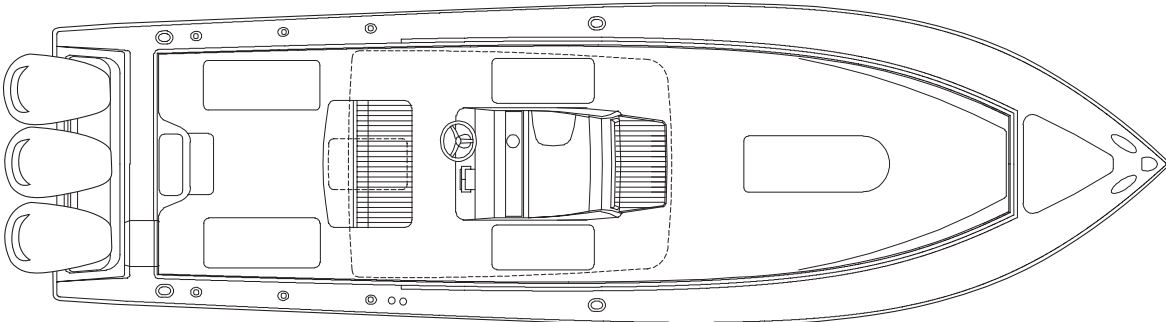

Jupiter 38 Tournament

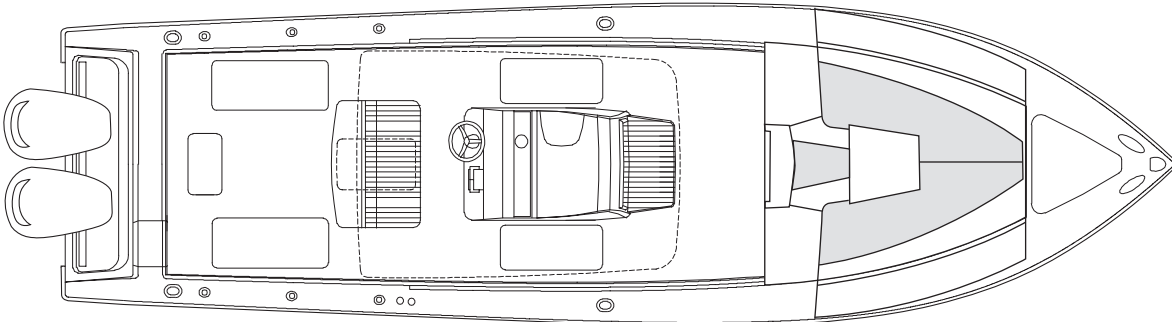

Jupiter 38 Cuddy

SPECIFICATIONS

L.O.A., Hull..... 38' 2"
 Beam 10' 7"
 Max HP Rating..... 1,050
 Bridge Clearance w/std T-Top..... 9'10"
 Deadrise,
 Forward..... 60°
 Aft 24°
 Dry Weight, (w/engines) 11,480 lbs.

Operating Weight (approx.) 13,350 lbs.
 Draft,
 Motors Up..... 24"
 Motors Down..... 36"
 Fuel Capacity (std.) 330 gal.
 Fuel Capacity w/Optional Tank 80gal 410 gal.
 Fuel Capacity w/Optional 155 gal Tank 485 gal.
 Water Capacity 50 gal.

Drawings are not to scale and are intended to show layouts only. Features and locations on components may differ between models and may include some optional items. All prices are F.O.B. Factory. Prices and specifications are based on the latest information available at the time of publication approval. The right is reserved to make changes at any time, without notice, in specifications, prices, materials, colors, equipment and models or to discontinue models. Prices do not include dealer prep, freight and make ready.