

2012 STANDARD EQUIPMENT

CONSTRUCTION

Closed cell PVC foam coring
Deck mechanically fastened and
Fiberglass bonded to hull
Fiberglass uni-grid stringer system
Hand-laid with multidirectional biaxial
& triaxial knitted fiberglass
Hi-Tech composite construction
High density composite core transom
Inner liner integrally bonded to hull
No wood-no rot laminated design
Posi-stern hull pad design
Solid fiberglass bottom
Vinylester resin barrier to prevent osmotic
blistering

COCKPIT

Anchor locker, top loading
Boarding ladder & grab rail
Coaming Bolsters
Dry storage compartment fwd.
Fishbox with macerator 102 gal.
Forward dry storage compartments
2 ea., 65 gal.
Fresh water washdown
Grabrails at all std. seating locations
Molded fiberglass gasketed hatches
Non-skid decks, with self bailing cockpit
Rod holders, 4 ea.
Salt water washdown
Walk thru transom door
Livewell 35 gal.
Helm seat, prep center with seat, back, rod
holders, drink holders and tackle cabinet
Rod racks, port and Starboard

ELECTRICAL

All wiring tin coated copper
Battery parallel switch
Bonded electrical system
Circuit protection throughout
Cockpit lighting, indirect LED
Color coded & numbered wiring system
Courtesy light in console
Hi-water bilge alarm
International navigation lights
Marine horn, electric, dual
Switch panel w/indicator lights, custom
Vapor proof battery switches
Weather resistant switches
HD marine batteries, AGM

MECHANICAL

All fasteners, hinges and hardware are
stainless steel
Bilge pumps, automatic/manual (2) 2000 GPH
Bronze thru-hull fittings below waterline
Deck hardware, flush mounted, SS
Double SS hole clamps below waterline
Fuel filters/water separator(s) 10 micron
Fuel tank, HD marine aluminum, coal tar coated
Heavy duty vinyl rub rail w/SS insert
Sea-cocks on all below water thru-hulls
Trim tabs, recessed w/auto retract and indicators
Water tank w/gauge
Livewell pump, HD 1600 GPH

CONSOLE

Battery storage compartment
Compass, high speed
Console seat with cushions & handrails
Custom ss steering wheel
Easy access entry door to head, lockable
Electronics compartment at helm
Hydraulic helm unit, adjustable
Marine head, electric w/holding tank
Molded head compartment
Molded insulated drink cooler
Plexiglass windscreen
Power outlet, 12V
Recessed key switches
Stand up head compartment

RIGGING

Binnacle control w/power trim
Engine alarm system
Engine cables & harness
Fuel/water sensor w/alarm
Hull boot stripe w/accent
Hydraulic steering
SS propellers matched to engines
Premium multifunction instrumentation
to include: tachometers, voltmeter, hour
meters, fuel gauges, water gauges, fuel
monitoring system

WARRANTY:

All Jupiter models are covered by a lifetime
transferable limited warranty. Copy of warranty
available upon request.



2012 PRICING

F/S

Single Yamaha F350, 4-stroke	\$116,950
Twin Yamaha F150, 4-stroke	\$119,990
Twin Yamaha F250, 4-stroke	\$138,790

GENERAL

Custom Towing Bit, HD Stainless Steel	1,950
GPS Mast, 3-Prong	695
Painted Hull Sides, Awlcraft	2,990
Painted Engines, Awlcraft, each	1,860
Painted underside of hardtop	990
Bomar hatch in console	970
Teak trim package, helm footrest and gauge trim	990

MECHANICAL/ELECTRICAL

Battery charger	795
Electronics Package, factory installed	P.O.R.
Cockpit lighting, 2 color upgrade	295
Power Assist Steering	2,350
Underwater Lights, LED, each	1,445
Windlass w/SS anchor and line	4,980

COCKPIT/FISHING

Custom T-top: w/fiberglass hardtop	9,995
Outriggers, T-top mounted	2,295
Extra rod holders, gunnel mounted, pr	295
Electronics box	1,990
Dive Door, Port side entry	P.O.R.

CANVAS & CUSHIONS

Console cover Helm/Electronics	295
Dodger w/zip-out window	1,680
Forward filler platform with cushion	1,290
Helm seat with wrap-around backrest	850
Cover, Tackle Center	495
Stern seat, removable	1,850
Two-tone upholstery upgrade	1,990
Console Enclosure, Polycarbonate	1,790
Console Enclosure, 3-Sided	3,190

Contact your local dealer or the factory for full listing of custom options

JUPITER TWENTY-SIX

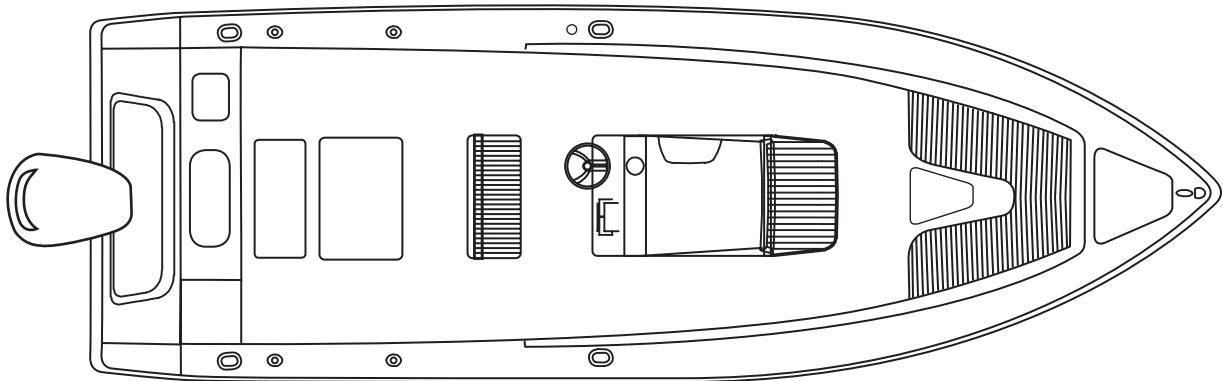
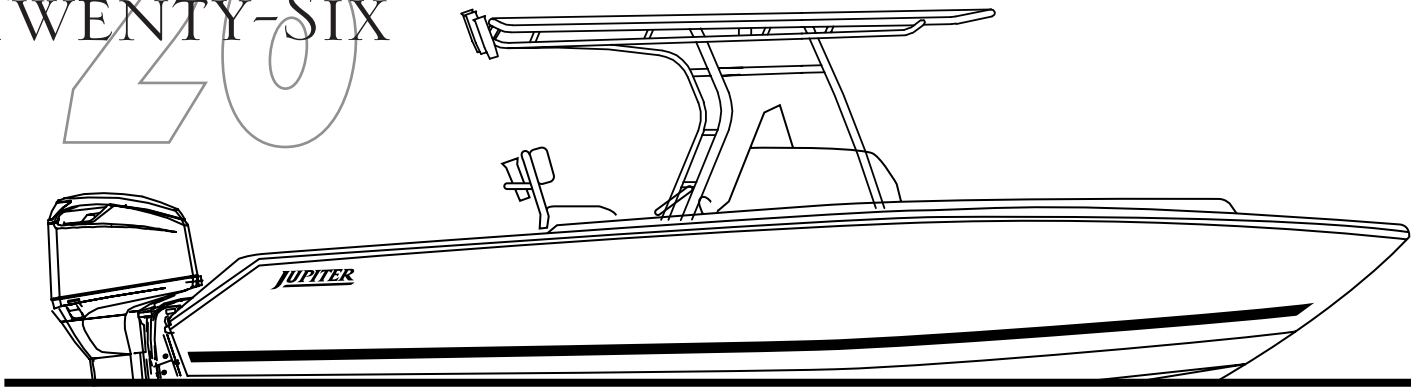

Jupiter 26 Forward Seating with single engine

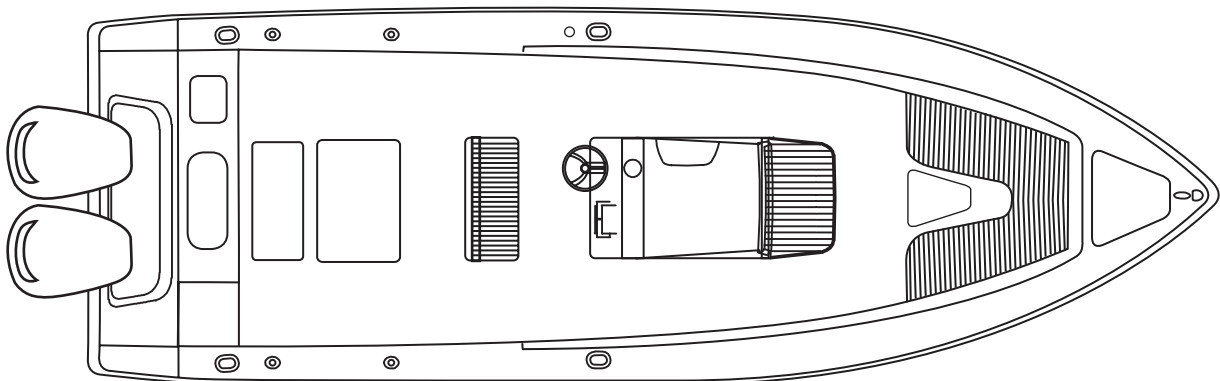

Jupiter 26 Forward Seating with twin engines

SPECIFICATIONS

L.O.A., Hull.....	26' 5"	Dry Weight, (w/engines)	5,460 lbs.
Beam.....	8' 8"	Operating Weight(Approx.)	6,400 lbs.
Max HP Rating.....	500	Draft, Motors Up	20"
Bridge Clearance w/std. T-Top.....	7' 10"	Draft, Motors Down.....	31"
Deadrise,		Fuel Capacity (std.)	160 gal.
Forward.....	60°	Water Capacity	30 gal.
Aft.....	23°		

Drawings are not to scale and are intended to show layouts only. Features and locations on components may differ between models and may include some optional items. All prices are F.O.B. Factory. Prices and specifications are based on the latest information available at the time of publication approval. The right is reserved to make changes at any time, without notice, in specifications, prices, materials, colors, equipment and models or to discontinue models. Prices do not include dealer prep, freight and make ready.